

CARE PUMP



User Manual

LITE 6

Lymph Drainage Therapy Device
(Pressotherapy Device)

UM_EN_CPLITE6_04

Table of contents

1. Safety warnings	4	5. Basic device configuration	16
1.1. Energy security	5	5.1. Main screen	16
1.2. Possibility of injuries	5	5.2. Work mode setting	16
1.3. Safe use and maintenance	6	5.3. Pressure level	17
1.4. Correct use of the cuffs	6	5.4. Treatment time	18
2. Basic characteristic of the device	7	5.5. Speed of filling the chambers	18
2.1. CarePump pressotherapy devices	7	5.6. Turning off individual chambers	19
2.2. Pressotherapy (lymphatic drainage massage) and its function	9	5.7. Information/Language settings	19
2.3. Indications for pressotherapy	9	5.8. How to start/pause/stop the treatment	20
2.4. Contraindications to pressotherapy	10	5.9. Provided programs	21
3. User manual	11	Mode A	21
3.1. CarePump Lite6 device – front view	11	Mode B	21
3.2. CarePump Lite6 device – back view	11	Mode C	22
4. Installation and starting the device	12	Mode D	22
4.1. How to connect the power supply	13	Mode E	23
4.2. How to connect the air ducts	14	Mode F	23
		6. Technical parameters	24
		7. Contents of the package	25
		8. Additional accessories	26

9. Warnings	27
10. Troubleshooting	28
11. Maintenance and storage	30
12. Utilization	32

1. **Safety warnings**

Before starting work with the device, please read the following manual. It is recommended to use the device after consulting a doctor.

CarePump series of devices has been designed in compliance with all safety standards and norms that allow them to be used. Please read the following chapter carefully, because it will allow you for safe and hygienic use of the device in accordance with its intended purpose.



The equipment can be used by children at least 8 years old and by people with reduced physical and mental abilities and people with inexperience and knowledge of the equipment, if supervision or instruction on the use of the equipment in a safe manner is provided so that the risks associated with it are understandable. Children should not play with the equipment. Children without supervision should not clean and maintain the equipment.

1.1. Energy security

CarePump series is powered by the mains voltage of 100-240V. Before connecting the device, make sure that the parameters of the transmission network are consistent with the data provided on the rating plate at the bottom of the case. The manufacturer recommends connecting the devices to an installation equipped with a residual current device. This will reduce the risk of shock, fire, permanent injury or damage of the product. In case of problems with the power supply, malfunctioning of the device, sparking or a burning smell emanating from the machine, immediately disconnect the device from the power supply by pulling the plug from the wall socket. It is forbidden to leave the device switched on without the operator's supervision or with the power plug inserted into the wall socket. In case of atmospheric discharges and storms, immediately stop the treatment and disconnect the device's power supply as mentioned above.

When disconnecting the power supply, pull it by the plug, not the cable, as this may damage the cable and result in electric shock or fire. Make sure if the cable is not tightly coiled or twisted, as this may damage it. Do not use damaged or stripped cable.

Be sure to disconnect the device and operate it with dry hands.

1.2. Possibility of injuries

It is forbidden to use the device on patients:

- ▶ with an implanted artificial heart and other heart prostheses,
- ▶ with metal or joint implants, as the procedure may cause inflammation or chronic pain around them,
- ▶ with heart disease,
- ▶ with decompensated blood pressure,
- ▶ with skin diseases and its inflammations,
- ▶ with a fever,
- ▶ with neoplastic disease,
- ▶ with vascular diseases,
- ▶ with acute dermatitis and festering wounds,
- ▶ deep vein inflammation and venous thrombosis,
- ▶ after surgical operations until full recovery,
- ▶ with diseases of the nervous system and brain,
- ▶ pregnant,
- ▶ extremely tired,
- ▶ under the influence of alcohol and other stimulants,
- ▶ with diseases that give the feeling of constant fatigue.

1.3. Safe use and maintenance

The device's operating environment should meet the following conditions. Non-compliance with them may result in personal injury or permanent damage of the device.

Working conditions

- ▶ closed room,
- ▶ ambient temperature 0°C - 40°C,
- ▶ ambient humidity approx. 60%,
- ▶ 100-240V mains supply, appropriately supervised by technical services,
- ▶ the distance from other electromagnetic receivers/transmitters should be min. 1,5 m,
- ▶ the distance from devices emitting heat should be min. 3 m,
- ▶ the distance from other electrical devices should be min. 1,5 m,
- ▶ the floor should be made of non-conductive materials,
- ▶ the ground on which the device is located should be stable, made of non-conductive and non-slip materials,
- ▶ the device should not be exposed to direct sunlight.

1.4. Correct use of the cuffs

Safe use of the device cuffs contains the following principles:

- ▶ Before putting on the cuffs, remove your watch, jewellery and empty the pockets to avoid any injury to the body or damage of the cuff.
- ▶ Do not place the cuffs directly on the body.
- ▶ The cuffs should be placed on thin, non-pressing clothing.
- ▶ Do not store cuffs near sharp objects or in wet, sunny and hot places.
- ▶ Do not expose the cuffs to staining with oil, gasoline, alcohol, corrosive chemicals.

2. Basic characteristic of the device

2.1. CarePump pressotherapy devices

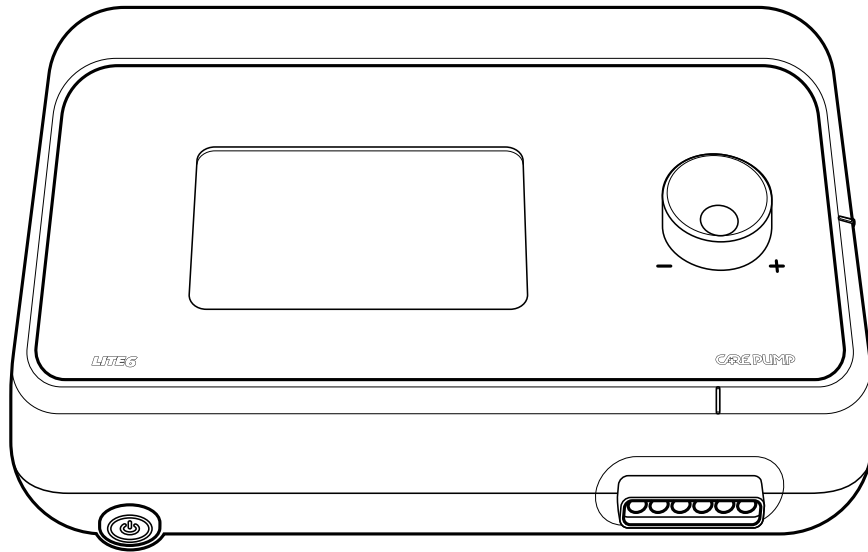

CarePump is a series of pressotherapy devices designed and manufactured as a result of many years of experience and research conducted by physiotherapy masters. Consultations with our clients regarding necessary functions, exploitation and comfort of use allowed us to create a diversified line of devices adjusted to every need of medical staff, patients, athletes and all other users.

CarePump devices are used for regeneration, relaxation and improving your well-being. The device works very similar to manual massage, which can be performed on your own body. This is executed on the principle of a pressure massage. Massage is performed by air-filled chambers placed in the cuffs, to which air is supplied through a system of flexible pipes from the central unit containing the compressor. Each cuff contains a plurality of independent chambers, which are sequentially inflated according to selected program.

The basic set that allows you to perform the treatment with CarePump device includes:

- A** **Central unit (device)** – used to set parameters such as: time, program, speed of pumping the chambers in the cuffs or pressure.
- B** **Air ducts** – used to supply air through independent channels to the individual cuff chambers. They connect the device with the cuffs.
- C** **Cuffs** – used on individual parts of the body (arms, legs, etc.). By sequential inflation of the cuff chambers, a part of the body (where the cuff is placed) is being compressed to allow achieving a massage effect.

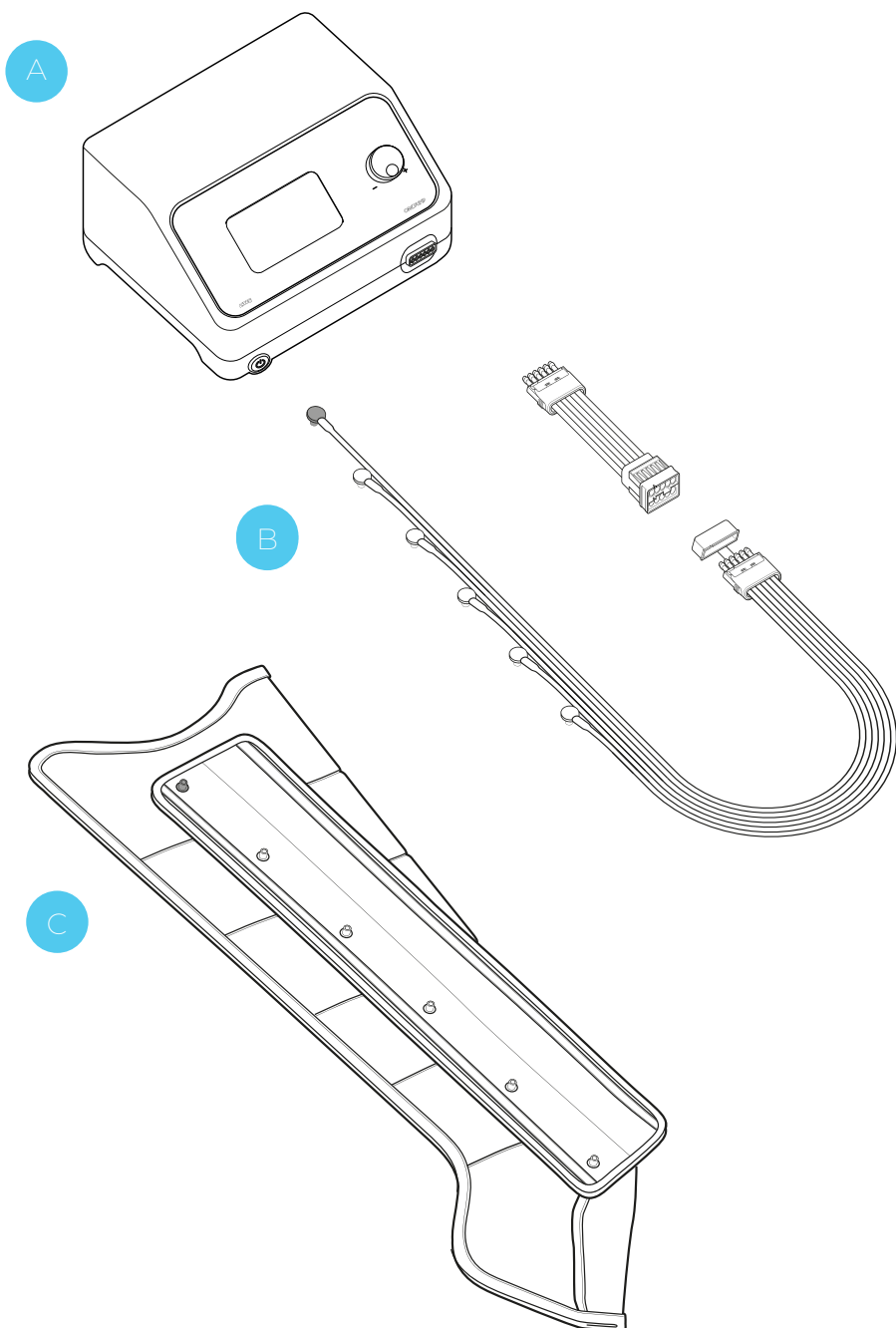

2.2. **Pressotherapy (lymphatic drainage massage) and its function**

Pressotherapy consists of sequential and directional pressure on a part of the body, where dedicated cuff is placed. The air-filled cuff chamber (by pneumatic compression) induces a mechanical massage effect. Particular chambers fill in with air in specified time and accordingly to programmed cycle. This causes a sequential pressure effect which turns into a rhythmic wave. Lymphatic drainage massage is positively perceived as a very pleasant and effective way to regenerate and relax. The patient feels relief in the areas covered by the massage.

During this type of massage similar physiological processes take place as in manual massage. It mainly stimulates the activity of the body, restores and stimulates its functioning, improves the flow and accelerates the exchange of fluids in the system. The benefits are also the same as in classic manual massage:

- ▶ regeneration,
- ▶ relaxation,
- ▶ improved well-being,
- ▶ improved skin elasticity,
- ▶ preventive healthcare.

Possible side effects of pressotherapy include:

- ▶ short-term pain exacerbation,
- ▶ petechiae,
- ▶ hematomas and bruises.

2.3. **Indications for pressotherapy**

It is recommended to perform pressotherapy every day. Work mode, time of the treatment and drainage / massage pressure depend on the individual preferences and possibilities, the aim of the treatment and applied prevention.

- ▶ increase the body's resistance,
- ▶ stimulation of metabolism and restoration of its function,
- ▶ prevention and treatment of overweight and obesity,
- ▶ reduction of swelling,
- ▶ improving regeneration of tired and sore muscles,
- ▶ exudates,
- ▶ cellulite,
- ▶ heavy legs
- ▶ and others the same as in classic manual massage.

2.4. **Contraindications to pressotherapy**

- ▶ pain or numbness of unknown origin,
- ▶ severe atherosclerosis or ischemia,
- ▶ vascular diseases are a relative contraindication to pressotherapy,
- ▶ pregnancy,
- ▶ hypertension,
- ▶ pacemaker,
- ▶ thrombophlebitis,
- ▶ skin diseases, moles,
- ▶ lymphangitis,
- ▶ dermatitis, wounds,
- ▶ arthritis,
- ▶ high body temperature,
- ▶ thick, external, visible varicose veins,
- ▶ cardiac rhythm disturbances (arrhythmia),
- ▶ blood pressure disorders,
- ▶ myocardial ischemia,
- ▶ asthma,
- ▶ tumors, infiltrates, neoplasms,
- ▶ cardiac and respiratory failure,
- ▶ kidney failure
- ▶ and others the same as in classic manual massage.

3. **User manual**

It is absolutely necessary to read following user manual before starting work with the device.

3.1. **CarePump Lite6 device - front view**

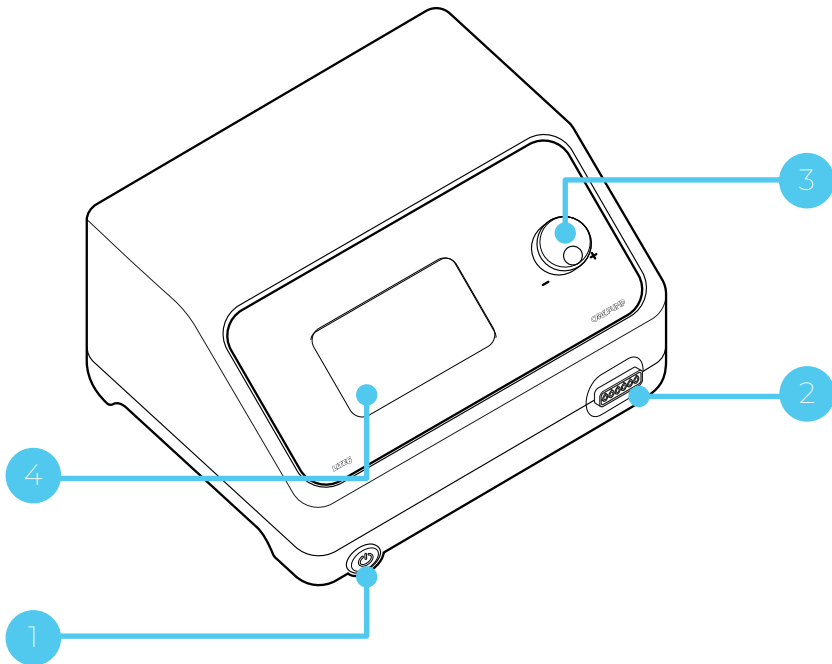

- 1 main power switch
- 2 input to connect the air ducts
- 3 adjustment knob
- 4 touch screen display

3.2. **CarePump Lite6 device - back view**

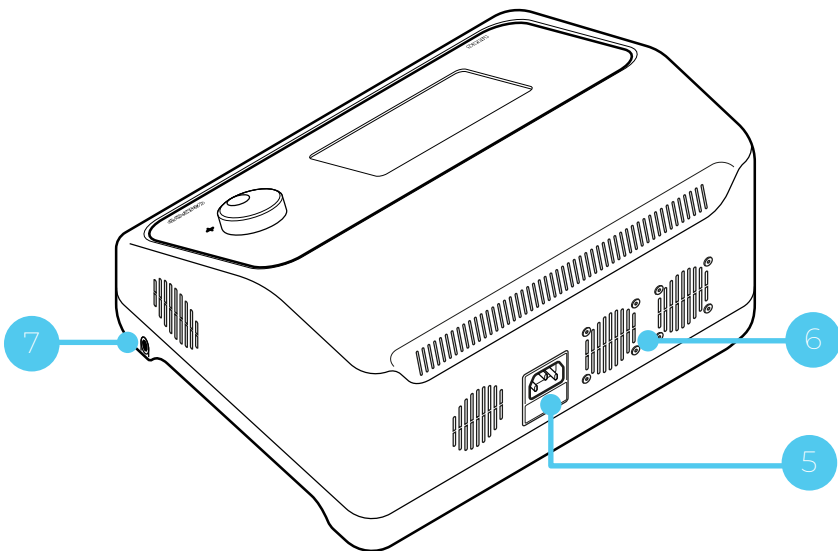

- 5 power cord input
- 6 holes of cooling fans
- 7 safety button input

4. **Installation and starting the device**

Before starting the device, check the completeness of the set and make sure if it has no defects or mechanical damage. In case of any noticed damage, contact the distributor or manufacturer of the device. Do not proceed with the installation and starting the machine if the packaging is damaged. Unpack the device and place it on a stable surface adequate for its weight. Remember not to place the device too close to the wall, because the holes of cooling fans are located on the back of the case. Do not place on or near the device other electrical devices that may generate electromagnetic field or high temperature and objects containing water or other liquids.

When the device is delivered in autumn or winter months, when the ambient temperature is below 10°C, wait about 2 hours before starting the device to equilibrate the temperature of the room and the device. The condensation of water vapor may cause an electric shock or fire.

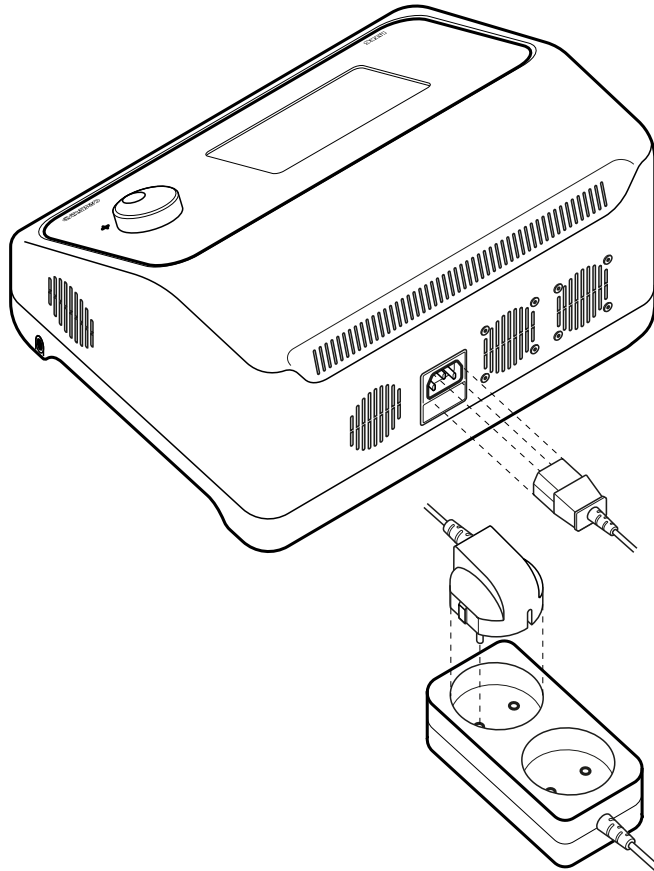

4.1. **How to connect the power supply**

Connect the power cord into the input on the back of the device. The cable should be fully inserted, please make sure it is firmly connected. Plug the other end of the cord into a power socket.



Attention!

- ▶ Use the supplied power cord or one that complies with electrical standards.
- ▶ Make sure that the voltage in the installation is 100-240V 50/60Hz.
- ▶ If the cable is mechanically damaged, replace it with another one.
- ▶ Do not place the machine close to the wall, because the holes of cooling fans and power cord input are located on the back of the case.

A

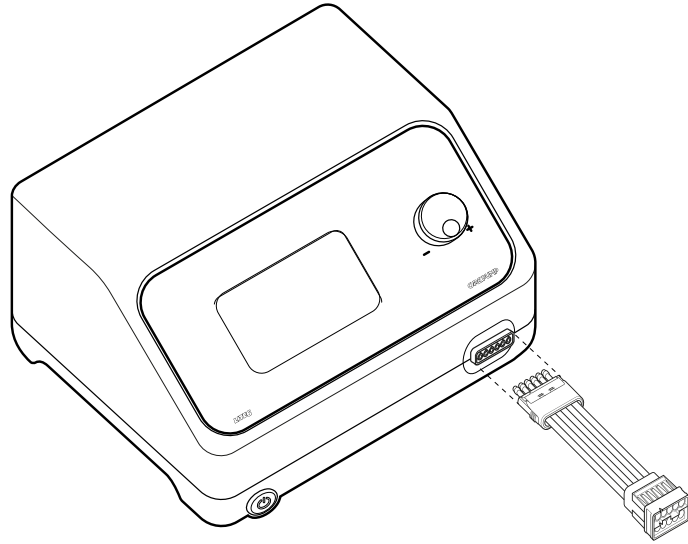

B

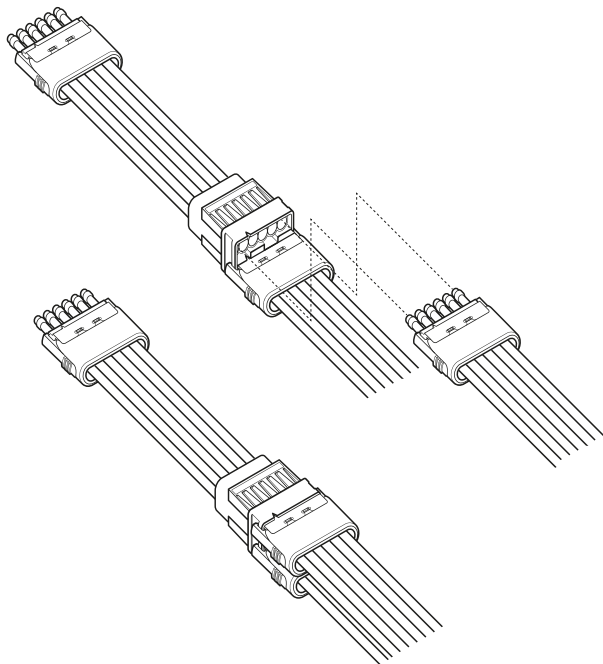

4.2. How to connect the air ducts

A

Connect the plug of a single air duct or the air duct splitter (in case you need to connect two cuffs at the same time) to the input located on the front of the case. When connecting the air duct or the splitter, pay attention to the notch which indicates proper connection of them.

B

To connect the air duct, push it into the correct input until you hear a click of both side buttons. To disconnect the air duct, press buttons on both sides of the plug at the same time.

When connecting two single air ducts to the splitter, pay attention to the notch which indicates proper connection of them.

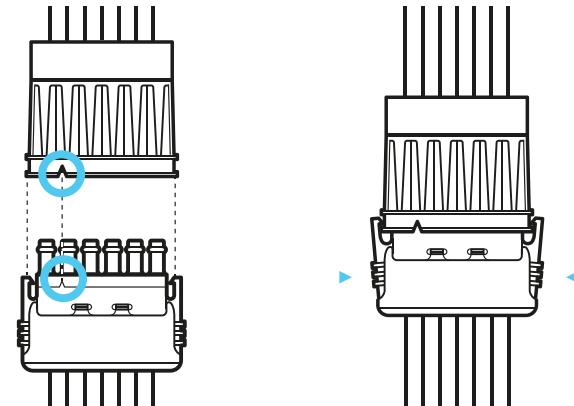

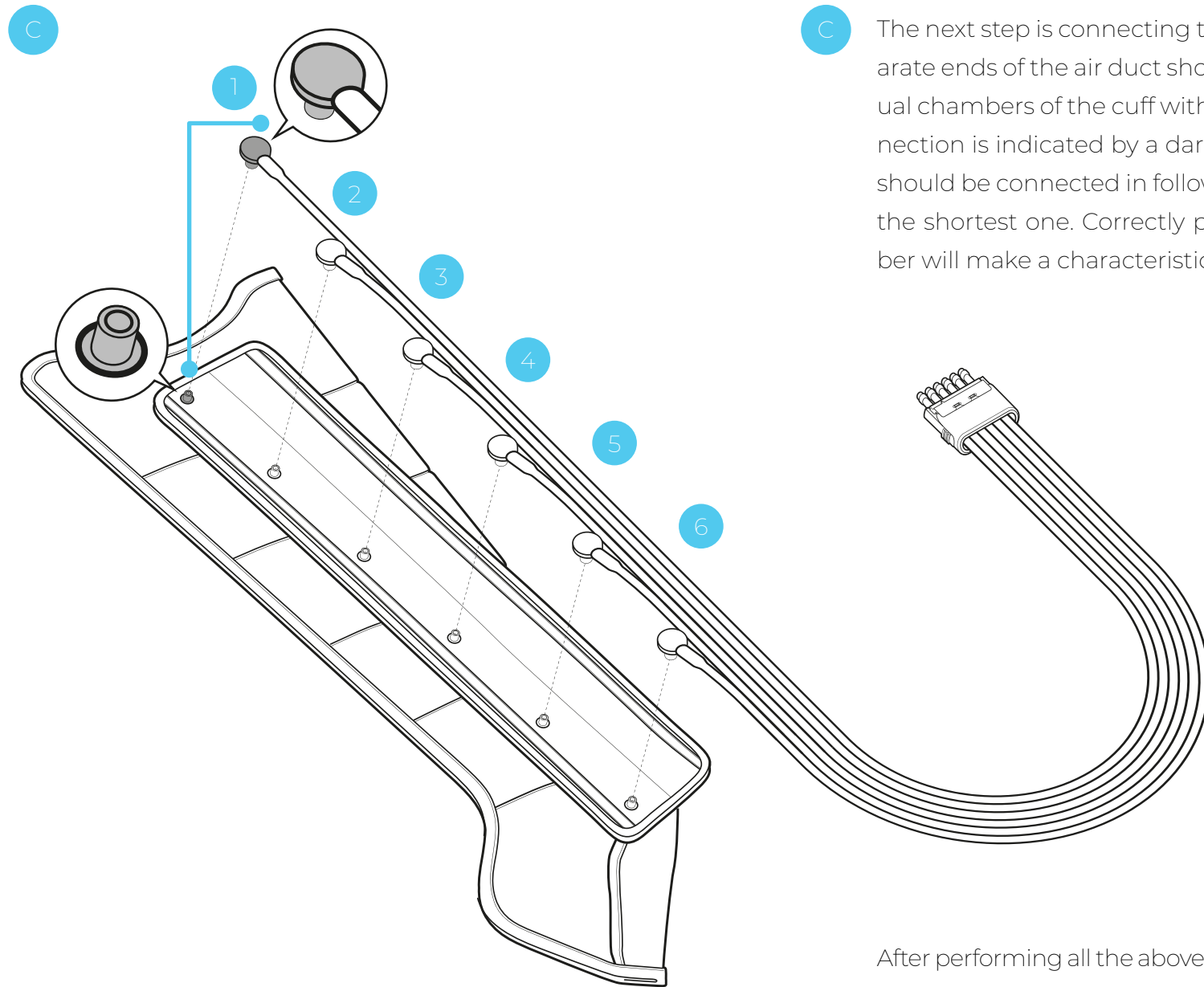

C The next step is connecting the air duct to the cuff. The separate ends of the air duct should be clipped into the individual chambers of the cuff with correct order. The proper connection is indicated by a dark gray plug. The separate ends should be connected in following order: from the longest to the shortest one. Correctly plugged end in the cuff chamber will make a characteristic click.

After performing all the above steps, the device is ready for use.

5. Basic device configuration

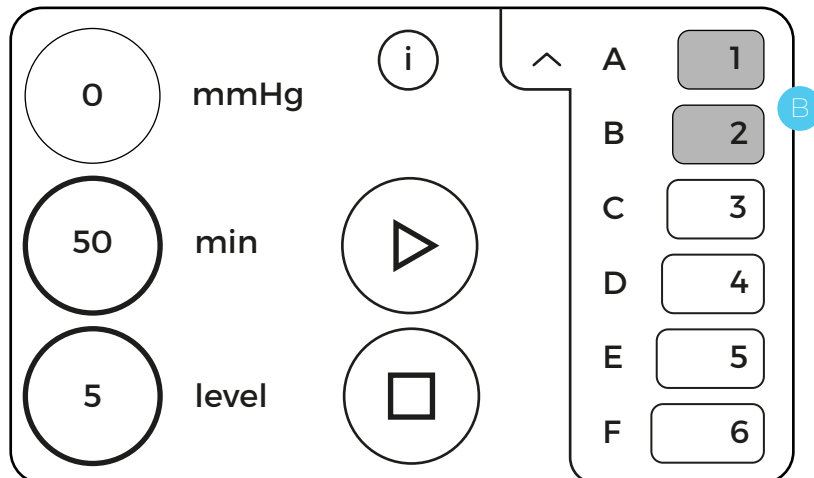
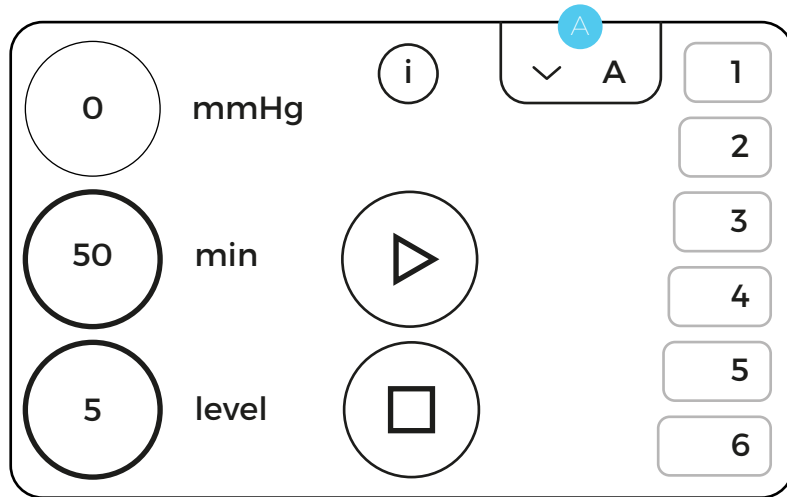

5.1. Main screen



To start the device, press the power button on the left side of the case. The blue diode will light up when the button is pushed. The device will start up and CarePump logo will appear on the display. Then the main screen view will appear, where you can set basic treatment options.

5.2. Work mode setting

To select one of the six provided programs, expand the alphabetical list in the upper right corner of the display **A**. The particular work modes are marked with the letters A, B, C, D. After pressing each letter, an animation will start showing how the chambers are pumping **B** and the default treatment time for the current mode will change. To select a work mode, press the corresponding letter, which will be highlighted in white. The selected work mode will appear in the window with the list of all provided programs **A**.



5.3. Pressure level

To set the pressure level, press the circle with the number “0” next to the pressure unit „mmHg” . The pressure value must be set using the adjustment knob. By turning to the right in the direction of “+”, the pressure will increase. By turning to the left in the direction of “-”, the pressure level will decrease. The current pressure value will appear in a circle next to the pressure unit “mmHg” . The pressure range generated by the machine is **20-220 mmHg**.

To confirm the pressure selection, press any icon on the display.

Attention!

Pressure as a parameter is not defined for provided programs. It should be adapted to the needs of each patient, based on the patient’s blood pressure and his feelings during the treatment.



5.4. Treatment time

To set the treatment time, press the circle next to the time unit „min” **D**. The treatment time is default for each of the work modes. The treatment time range that can be set in the device is **1-120 minutes**. The treatment time should be set by using the adjustment knob. By turning it to the right in the direction of “+”, the treatment time will be extended with another minute. By turning it to the left in the direction of “-”, the treatment time will be shortened. The current treatment time will be displayed in a circle next to the time unit “min”. To confirm the selection of the treatment time, press any icon on the display.

5.5. Speed of filling the chambers

To set the speed of filling the chambers, press the circle next to the parameter “level” **E**. By default, the speed of filling the chambers is set to level 5. The chamber inflation speed range is 1-5, with 1 being the lowest (slowest filling) and 5 being the highest (fastest filling). The chamber inflation speed should be set using the knob. To confirm the selection, press any icon on the display.



5.6. Turning off individual chambers

The device allows you to turn off the chambers in the cuff that need to be bypassed (they will not be inflated with air) during the treatment. By default, all chambers are turned on. To turn off a particular chamber, press the corresponding number on the graphic image of the cuff on the right side of the screen. After the chamber is turned off, its number will stop being highlighted. To turn the chamber back on, press the number of the chamber again.

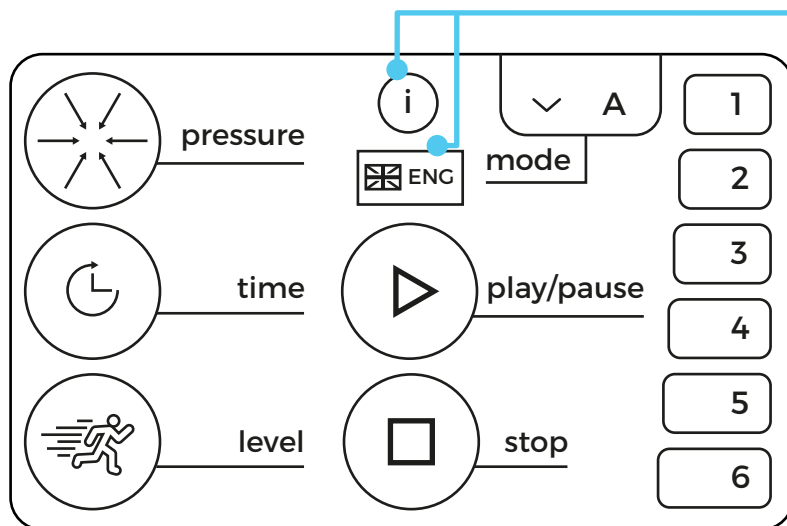

5.7. Information/Language settings

After pressing "i" button, the icons explaining the settings available on the start screen will be displayed. This view also allows you to change the language by clicking on the square with the abbreviation corresponding to the particular language. To return to the main screen, press any icon on the display.

5.8. How to start/pause/stop the treatment

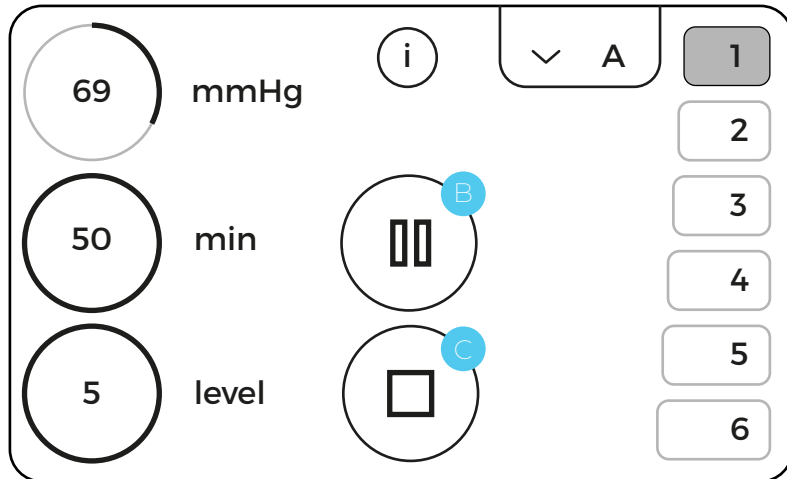
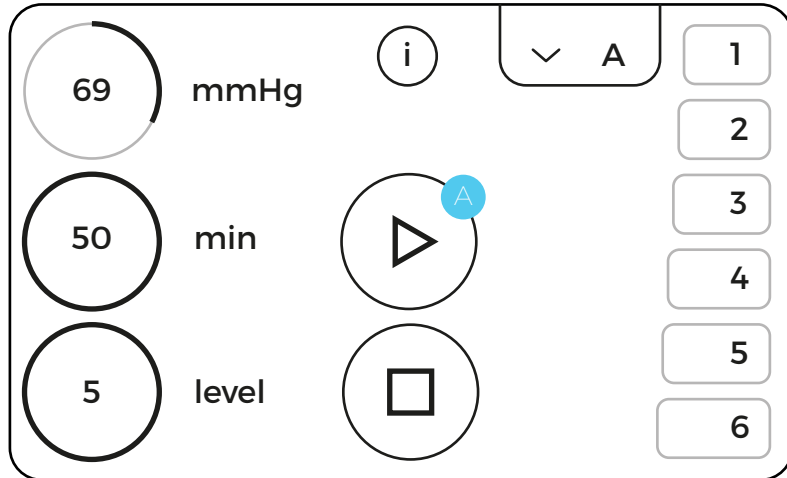

After setting the parameters, you can start the treatment. To start the treatment, press the icon **“play”** **A** in the center of the display. After pressing it, the treatment will start and this will be shown by the blinking chamber on the graphic image of the cuff and the elapsing time.

To temporarily stop the treatment, press the **“pause”** icon **B**. The treatment will stop and the treatment time will be paused. The treatment can be resumed by pressing the icon “play” again.

To permanently stop the treatment, press the icon **“stop”** **C**. When treatment is completely stopped, the unit will return to its pre-treatment settings and the air will be pumped out of the cuffs.

5.9. Provided programs

The device has four provided work/massage modes.

A

mode **A**

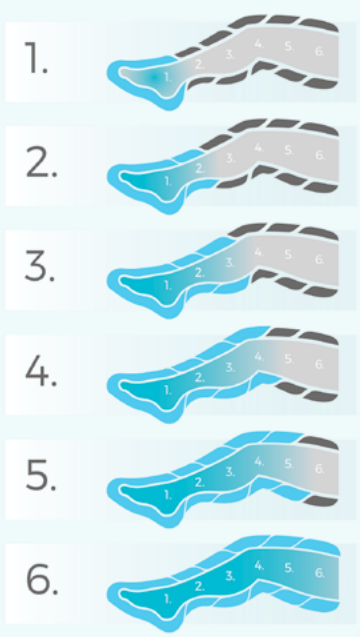

The diagram illustrates the sequence of six steps for Mode A. Each step shows a foot with six numbered chambers (1-6) along the arch. The chambers are filled sequentially from 1 to 6, with the previously filled chambers remaining inflated. The blue shading indicates the current chamber being filled.

Time	50 min.
Hold	3 s
Interval	3 s

B

mode **B**

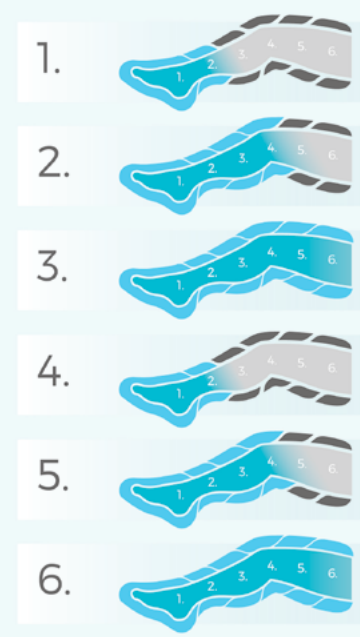

The diagram illustrates the sequence of six steps for Mode B. Each step shows a foot with six numbered chambers (1-6) along the arch. In each step, two consecutive chambers are filled simultaneously, while the previously filled chambers remain inflated. The blue shading indicates the two chambers being filled.

Time	50 min.
Hold	3 s
Interval	3 s

A Mode A

The course of the treatment:

Single filling of consecutive chambers while keeping the pressure in previously inflated chambers.

- ▶ Time: 50 min.
- ▶ Interval: 3 s
- ▶ Hold: 3 s

B Mode B

The course of the treatment:

Simultaneous filling of two consecutive chambers while keeping the pressure in the previously inflated chambers.

- ▶ Time: 50 min.
- ▶ Interval: 3 s
- ▶ Hold: 3 s

C

mode **C**

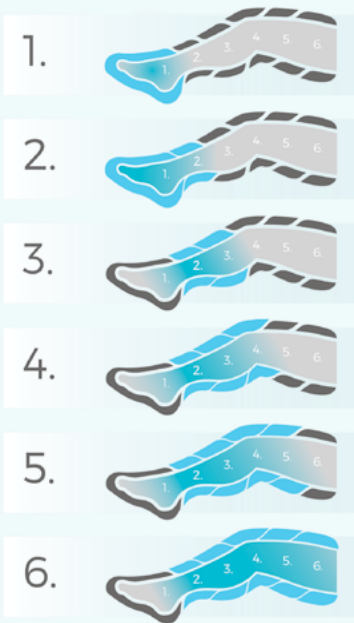

Time	60 min.
Hold	3 s
Interval	3 s

D

mode **D**

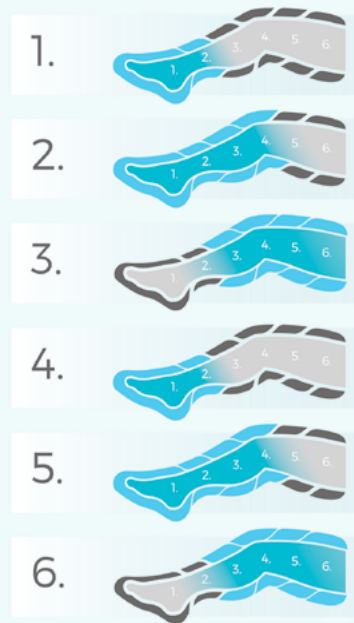

Time	45 min.
Hold	2 s
Interval	2 s

C

Mode C

The course of the treatment:

Single filling of consecutive chambers while keeping the pressure in the previous inflated chambers, with the exception of the first inflated chamber, which deflates during pumping of the third one.

- ▶ Time: 60 min.
- ▶ Interval: 3 s
- ▶ Hold: 3 s

D

Mode D

The course of the treatment:

The chambers pump up in pairs. After the first and second chambers are inflated, the third and fourth ones are filled. When filling the fifth and sixth chambers, the first and second ones deflate. The cycle begins again when the fifth and sixth chambers are fully inflated.

- ▶ Time: 45 min.
- ▶ Interval: 2 s
- ▶ Hold: 2 s

E

mode **E**

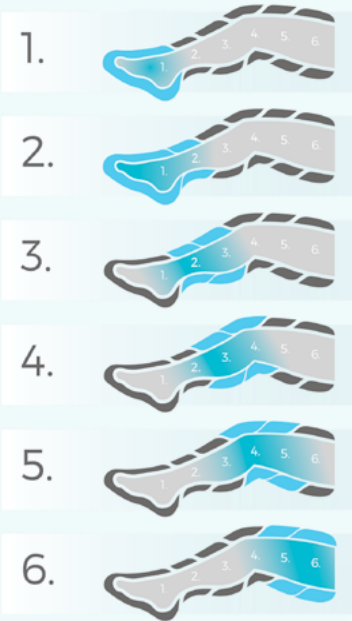

Time	60 min.
Hold	2 s
Interval	2 s

F

mode **F**

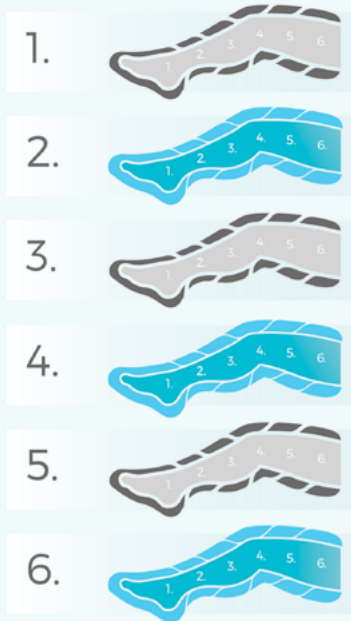

Time	30 min.
Hold	2 s
Interval	3 s

E

Mode E

The course of the treatment:

The chambers pump up one after another. After the second chamber is inflated, the third one begins to inflate and the first one deflates at the same time. When filling the fourth chamber, the second one deflates. The cycle ends when the sixth chamber is filled in this sequence.

- ▶ Time: 60 min.
- ▶ Interval: 2 s
- ▶ Hold: 2 s

F

Mode F

The course of the treatment:

All chambers inflate simultaneously and keep the pressure, performing a global massage.

- ▶ Time: 60 min.
- ▶ Interval: 3 s
- ▶ Hold: 2 s

6. Technical parameters

Number of chambers	6
Max. pressure [mmHg]	220
Number of proprietary therapeutic pre-programs of the medical organization	6
Precise regulation of pressure and time	in steps of 1
Number of independent channels	1
Adjustment of the speed of the treatment	1-5
Cuffs	system overlapping
Display	5" TN lcd color touch screen
Weight [kg]	3,1
Dimensions [mm]	300x260x160
Power supply	100÷240 V, 50÷60 Hz
Power consumption	40-70 W
Warranty	1 year

7.

Contents of the package

The basic CarePump set includes:

- A Central unit (device)
- B Power cord

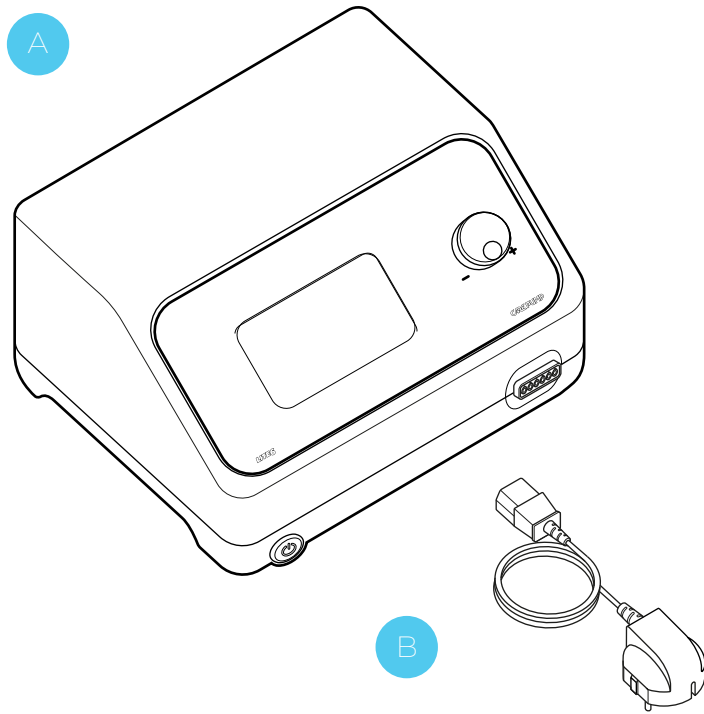

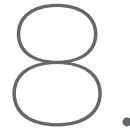
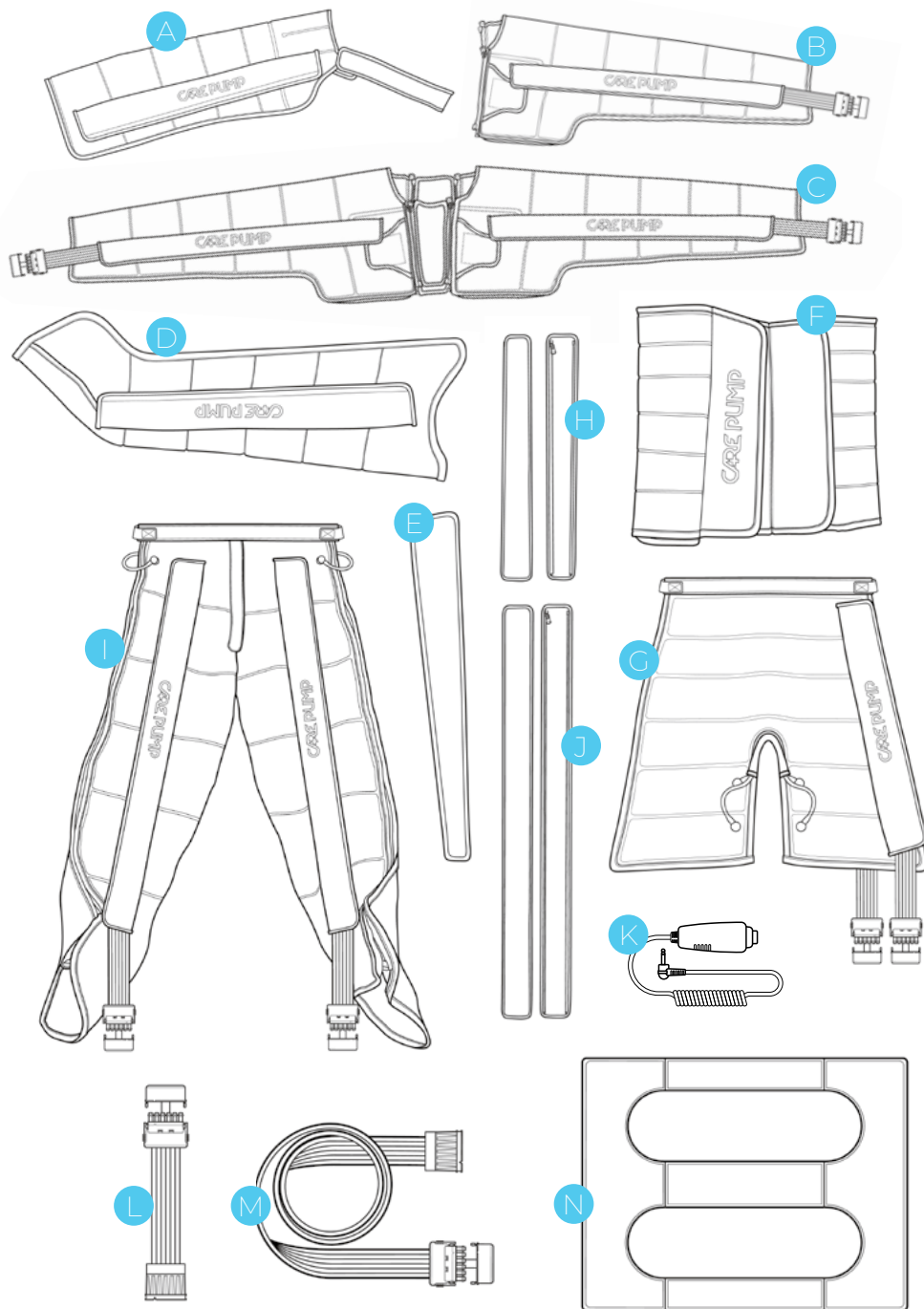

Additional accessories

The basic CarePump Lite6 set can be expanded with the following accessories. Air ducts are provided with the cuffs.

- A arm cuff
- B arm, shoulder and chest cuff
- C double cuff for arms, shoulders and chest with extenders
- D leg cuff
- E leg cuff extension zipper
- F waist cuff
- G short pants
- H short pants extension zippers (2 pcs.)
- I full pants
- J full pants extension zippers (2 pcs.)
- K patient's safety button enabling emergency termination of the treatment
- L double splitter for simultaneous connection of two cuffs to the device
- M long double splitter (1,5 m)
- N pressotherapy wedge for legs

9.

Warnings

Before starting work with the device, it is obligatory to read the manual and follow all the recommendations.

Making technical changes to the device or using it in a manner inconsistent with the manual may result in the loss of warranty and in case of the need for intervention by an authorized service, may result in treating it as a commercial service.

The device must be used as described in this manual and with original components. Otherwise, the device may break down or the user may be injured.

10. Troubleshooting

In case of a failure, we recommend you to perform a few simple steps before contacting the service. This will eliminate the situation in which the device will not be damaged or it will be easier to receive help from an authorized service center.

PROBLEM	CHECK
Device turns on and there is a pumping sound, but the cuff does not inflate.	Check if there is any leakage in the air duct or cuff or if they are properly connected. Attach another cuff and air duct from the set in different configurations to identify the damaged component. If the problem persists after connecting other accessories, contact an authorized service center or the manufacturer.
The touch screen works incorrectly or it does not work at all.	Disconnect the device from the power supply. Clean the front panel with a cloth and optical cleaning fluid to remove any dirt. If the problem persists after performing the above steps, contact an authorized service center or the manufacturer.
The device does not turn on.	Check if the cable is plugged into a power socket. In addition, check if the power button is in "ON" position and its blue diode is on. If that does not help, replace the electric fuse in the power input. If the problem persists after performing the above steps, contact an authorized service center or the manufacturer.

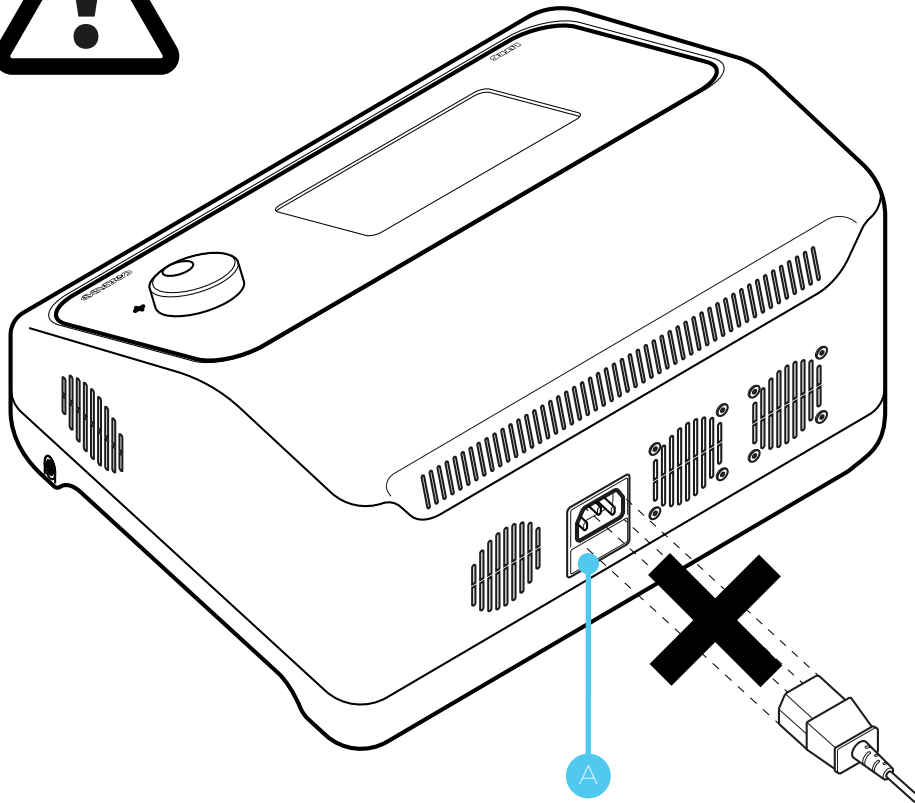

THE FUSE REPLACEMENT



Attention!

Before proceeding with checking the fuse, it is absolutely necessary to disconnect the device from the power supply!

To check or replace the fuse, locate the power input on the back of the case. Below the socket for the power cord, there is a fuse drawer **A**. Open it and pull out the glass fuses placed inside. If the plate inside the glass fuse is intact, it means that the fuse is working properly and it does not need to be replaced. If the plate is broken/burned out, the fuse should be replaced with a new working one and then the drawer may be closed.

11. Maintenance and storage

- ▶ If the device is used as intended, the machine does not require any special maintenance.
- ▶ Try to keep the cuffs clean and regularly wipe the main screen of the device.
- ▶ In case of a failure, first perform the actions described in the previous section.
- ▶ The device should be regularly checked by an authorized service, preferably every 12 months.
- ▶ If you experience any failure with your machine or its accessories, or if you notice a device malfunction, contact the distributor immediately.
- ▶ In case of any disturbance in the operation of the device, its damage or suspicion of damage, stop using it immediately.
- ▶ Under no circumstances should a damaged device be started. All repairs and maintenance may be performed only by the manufacturer or an authorized service center. In case of independent repairs, the distributor of the device is not responsible for any damage.

Recommendations for transporting the device:

- ▶ CarePump devices do not require any special precautions.
- ▶ It is recommended to store and transport the devices in the packed, original box with foam moldings.
- ▶ It is important not to bent the cables to reduce the risk of damaging them.

Recommended storage conditions for the device:

- ▶ ambient temperature : 5°C - 40°C
- ▶ relative humidity: 15 - 93%
- ▶ pressure: 700 - 1060 hPa

Device service

In case of a failure, repairs may only be carried out by an authorized service center with personnel trained by the manufacturer. In case of problems with locating the service, please contact the device distributor.

Only an authorized service center is qualified to repair the device. Otherwise, making any changes by an unauthorized entity may result in the loss of warranty.

Cleaning and disinfection

Clean the device from dust and dirt with a soft, linen cloth.

More difficult stains should be washed with a damp sponge with a cleaning liquid based on water and alcohol (20% alcohol).

Do not clean the area of the power input, safety button and ventilation holes with a damp cloth. This area should be cleaned with a dry cloth.

12. Utilization

The product is regulated by WEEE, regarding waste segregation, as indicated by the following symbol on the label of the device:

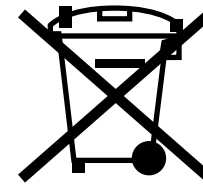

The product should be disposed of in dedicated places and points for electronic waste and in accordance with the prevailing law in the country where the device was used.

Declaration of Conformity

We

Bardomed Sp. z o.o

ul. Konecznego 6/66
Postal-code: 31-216 Kraków
<https://www.bardomed.pl>

under own responsibility hereby declare that the following product(s):

Type of equipment:	massage device
Type designation/models:	Carepump Compact 4, Carepump Expert 8, Carepump Lite 4, Carepump Lite 6.

are in conformity with the provisions of the following EC directives:

EC Electromagnetic Compatibility (EMC) Directive 2014/30/EU

EC Low Voltage Directive (LVD) 2014/35/EU

EC RoHS 2011/65/UE



and that the technical standards referenced below have been applied:

**PN-EN 61000-4-2:2011, PN-EN 61000-4-3:2021, PN-EN 61000-4-4:2013-05,
PN-EN 61000-4-5:2014-10/A1:2018-01, PN-EN 61000-4-6:2014-10,
PN-EN 61000-4-8:2010,
PN-EN 61000-4-11:2020-11, PN-EN 61000-3-2:2019-04,
PN-EN 61000-3-3:2013-10,
PN-EN 55011:2016-05/A1:2017-06
PN-EN 60335-1:2012+A11:2014-10+A13:2017-11+A1:2019-10+AA:2019-11
PN-EN 60335-2-32:2009+A2:2015-03
PN-EN 63000:2019-01**

Kraków, 2021-12-20

Bartosz Frydrych
Prezes Zarządu

Manufacturer



BardoMed Sp. z o.o.
ul. Konecznego 6/66
31-216 Kraków
NIP: 945217693